



Bobcat®

**COMPACT EXCAVATORS
E08**



One Tough Animal®

E08 — SPECIFICATIONS

Weights

Operating weight with TOPS canopy and bucket (ISO 6016)	1138 kg
Transport mass (no attachment)	1039 kg
Ground pressure with rubber tracks	28.80 kPa

Engine

Make / model	Kubota / D722-E4B-BCZ-6
Fuel	Diesel
Number of cylinders	3
Displacement	0.72 L
Maximum power @ 2000 rpm (ISO 14396)	7.5 kW
Maximum torque (SAE)	40.1 Nm

Performance

Digging force, dipperstick (ISO 6015)	5550 N
Digging force, bucket (ISO 6015)	8294 N
Drawbar pull	9905 N
Travel speed, low range	2.1 km/h

Hydraulic System

Pump type	Double gear pump
Pump capacity	20.00 L/min
Auxiliary flow	20.00 L/min
Auxiliary relief	185.0 bar

Slew System

Boom swing, left	67.0°
Boom swing, right	64.0°
Slew rate	9.0 RPM

Fluid Capacities

Cooling system	3.00 L
Engine lubrication plus oil filter	3.50 L
Fuel reservoir	16.00 L
Hydraulic reservoir	2.60 L
Hydraulic system	9.40 L

Environmental

Noise level LpA(EU Directive 2006/42/EC)	80 dB(A)
Noise level LWA(EU Directive 2000/14/EC)	93 dB(A)

Standard Features

710 mm dozer blade / 1000 mm extended	Retractable seat belt
180 mm rubber track	Seat
Auxiliary hydraulics	TOPS canopy ¹
Control console locks	Vandalism protection
Horn	Work lights
Hydraulically expandible undercarriage from 710 to 1000 mm	Warranty: 24 months, 2000 hours (whichever occurs first)

1. Tip Over Protective Structure (TOPS) – Meets requirements of ISO 12117

Working Range

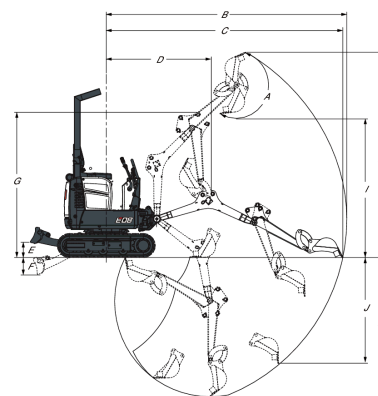

(A)	196.0°	(G)	1899.0 mm
(B)	3145.0 mm	(H)	2685.0 mm
(C)	3093.0 mm	(I)	1818.0 mm
(D)	1374.0 mm	(J)	1383.0 mm
(E)	196.0 mm	(K)	1820.0 mm
(F)	230.0 mm		

Dimensions

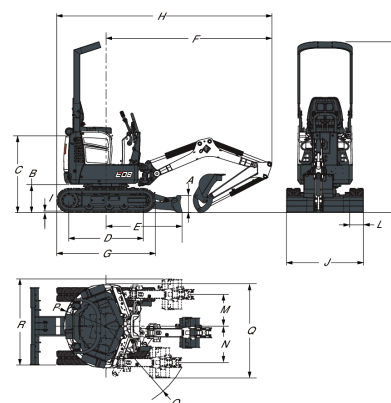

(A)	220.0 mm	(J)	1000.0 mm
(B)	363.0 mm	(K)	2209.0 mm
(C)	992.0 mm	(L)	180.0 mm
(D)	968.0 mm	(M)	413.0 mm
(E)	987.0 mm	(N)	471.0 mm
(F)	2153.0 mm	(O)	1121.0 mm
(G)	1280.0 mm	(P)	550.0 mm
(H)	2793.0 mm	(Q)	1220.0 mm
(I)	16.0 mm	(R)	1163.0 mm
(J)	710.0 mm		

Options

Auxiliary double action	Hydraulic oil cooler
Auxiliary on arm	Keyless ignition
Auxiliary quick coupler	Object handling device (lifteye)
Beacon	Spark arrester muffler kit
Heavy duty travel hose guard	Travel motion alarm



Bobcat is a Doosan Company.
Doosan is a global leader in construction equipment, power & water solutions, engines, and engineering proudly serving customers and communities for more than a century. Bobcat and the Bobcat logo are registered trademarks of Bobcat Company in the United States and various other countries.
©2019 Bobcat Company. All Rights Reserved.

Certain specification(s) are based on engineering calculations and are not actual measurements. Specification(s) are provided for comparison purposes only and are subject to change without notice. Specification(s) for your individual Bobcat equipment will vary based on normal variations in design, manufacturing, operating conditions, and other factors. Pictures of Bobcat units may show other than standard equipment.



Bobcat®

www.bobcat.com